

nXRi HIGH PERFORMANCE COMPACT DRY VACUUM PUMP

edwardsvacuum.com

Edwards has revolutionised the vacuum pump market with the new nXRi high performance, compact dry pump. It delivers unrivalled pumping speeds in the most compact package, with pumping speeds of 60 and 90 m³h⁻¹. The nXRi's lower input power and zero maintenance create real performance improvements and cost benefits across a range of applications.

Analytical Instrument OEMs benefit from the ease of integration into most vacuum systems for a ready to go vacuum solution, perfect for mass spectrometry, electron microscopy and leak detection. R&D and Industrial customers will enjoy the design flexibility, oil-free and low maintenance features.



Compact footprint
Optimise your space!

Unrivalled performance
When you need it!

Energy efficiency
Reduce your costs!

Zero contamination
Experience the difference!

Features and benefits

- 1 Designed with size in mind, the compact footprint and height allow the nXRi dry pump to fit easily under a benchtop saving valuable space in your laboratory; and at under 30kg offers a highly portable vacuum pump for changing work flows and environments.
- 2 When performance matters look no further than the nXRi dry pump, with pumping speed performance of 60 and 90 m³h⁻¹ from our most compact footprint. It delivers four times more pumping speed than similar sized dry pumps, and with low ultimate and high reliability you are assured a consistent and stable vacuum for years to come.
- 3 For reduced power consumption look no further than the Edwards nXRi dry pump, optimised to low power for lower energy costs and reduced heat load from your vacuum equipment.
- 4 Clean processes and clean results are guaranteed with the nXRi compact dry pump, being totally oil-free and dust-free within the vacuum chamber. Being free of oil, smells and particulates guarantees a more pleasant working environment.

Technical data

Peak pumping speed	
nXR60i	60 m ³ h ⁻¹
nXR90i	90 m ³ h ⁻¹
Ultimate vacuum (total pressure)	0.03 mbar (0.022 Torr)
Inlet flange	NW40
Outlet flange	NW25
Maximum permitted outlet pressure	
nXR60i	0.2 bar gauge
nXR90i	0.2 bar gauge
Operating temperature range	+5 to +40°C (+41 to +104°F)
Nominal rotational speed	15000 rpm
Voltage input	100-127/200-240 V (+/-10%), switchable
Mains frequency	50/60 Hz
Power connector 1-ph	IEC EN60320 C19
Power at ultimate	450 W
Leak tightness	< 1x10 ⁻⁶ mbar ls ⁻¹
Weight	29 kg (64 lb)
Noise at ultimate vacuum	55 dB(A)
Vibration at inlet flange	< 2.0 mm/s

Dimensions

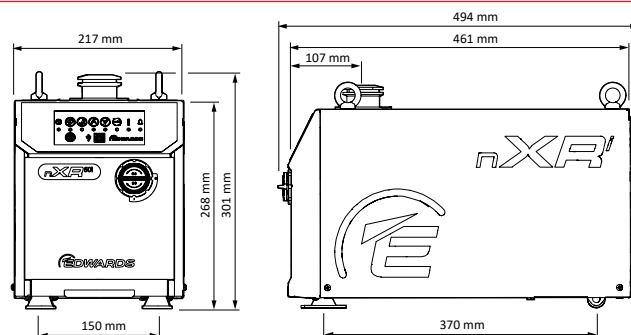

nXR60i/nXR90i pumping speed/pressure

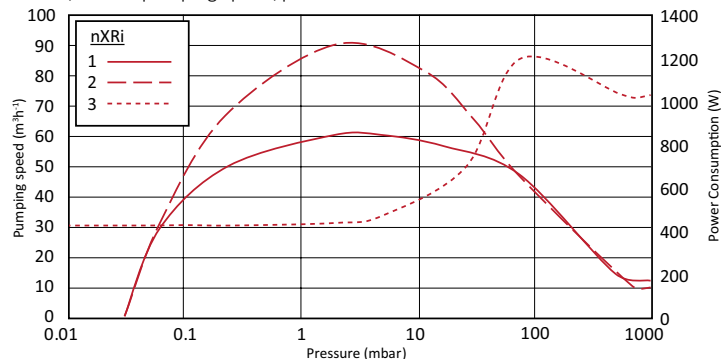

1. Pumping speed nXR60i 2. Pumping speed nXR90i 3. Power Consumption (W)

Ordering information

Product description	Order number
nXR60i NW40 Multi Stage Roots Dry Pump 100-127/200-240 V, 50/60 Hz	A90502983
nXR90i NW40 Multi Stage Roots Dry Pump 100-127/200-240 V, 50/60 Hz	A90602983

Accessories

Product description	Order number
2m electrical supply cable, NEMA 5-15P, North America/Japan (100-120 V)	A50507003
2m electrical supply cable, NEMA 6-15P, North America (200-240 V)	A50507006
2m electrical supply cable, UK, three pin plug	A50505003
2m electrical supply cable, Europe	A50506003
2m electrical supply cable, China	A50509003
Gas ballast blank plug	A73501806
Gas ballast adaptor for inert gas (1/4" quick connect)	A73501811
Floor/cart mounting kit	A90590001

GLOBAL CONTACTS

Publication Number: 3601 0600 01

© Edwards Limited 2020. All rights reserved. Edwards and the Edwards logo are trademarks of Edwards Limited.

Whilst we make every effort to ensure that we accurately describe our products and services, we give no guarantee as to the accuracy or completeness of any information provided in this datasheet.

Edwards Ltd, registered in England and Wales No. 6124750, registered office: Innovation Drive, Burgess Hill, West Sussex, RH15 9TW, UK.

EMEA		ASIA PACIFIC	
UK	+44 (0) 1444 253 000 (local rate) 0845 921 2223	China	+86 400 111 9618
Belgium	+44 1293 60 3350	India	+91 20 4075 2222
France	+33 1 4121 1256	Japan	+81 47 458 8836
Germany	0800 000 1456	Korea	+82 31 716 7070
Italy	+39 02 48 4471	Singapore	+65 6546 8408
Israel	+972 8 681 0633	Taiwan	+886 3758 1000
Russia	+7 495 933 55 50 Ext. 1800/1803 +8 800 775 80 99	AMERICAS	
		USA	+1 800 848 9800
		Brazil	+55 11 3952 5000

